

CHEVROLET G3500 DURAMEDIC

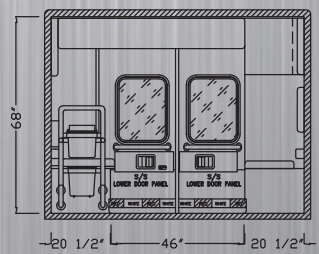

Road Rescue®
In Service for Life™

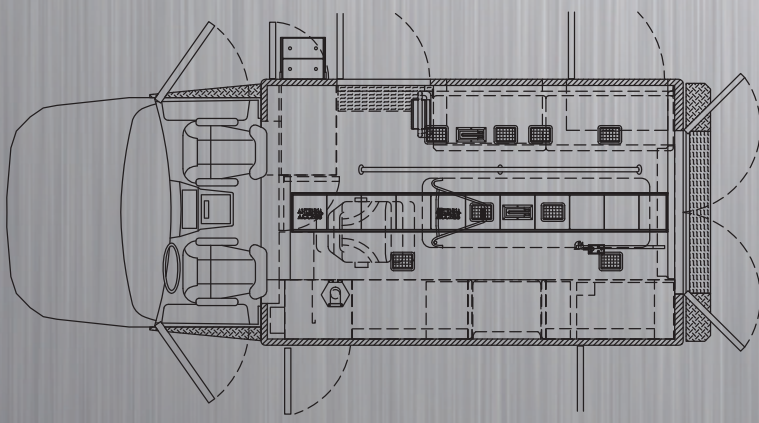
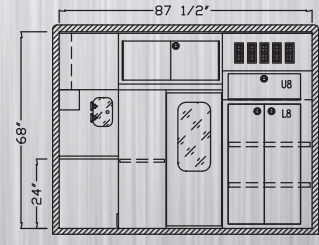
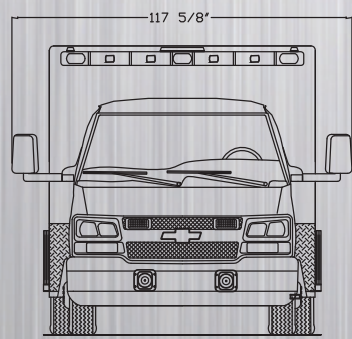
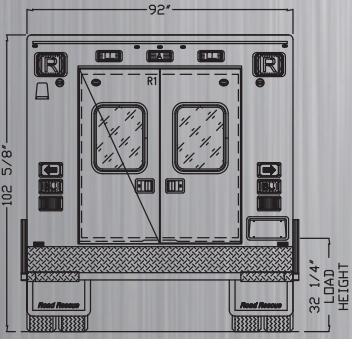
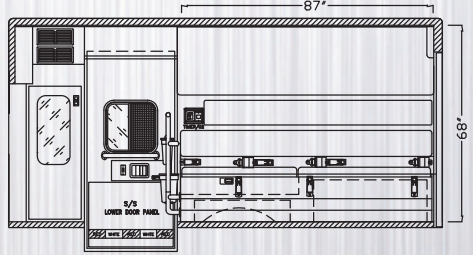
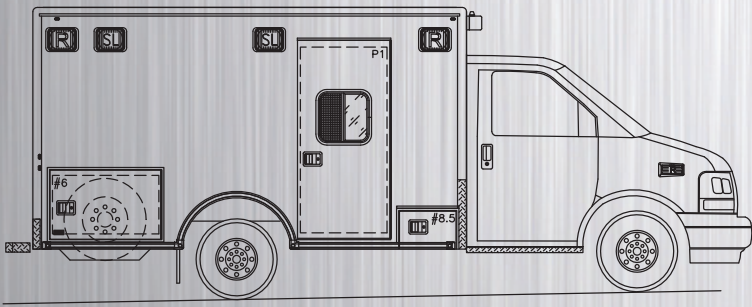
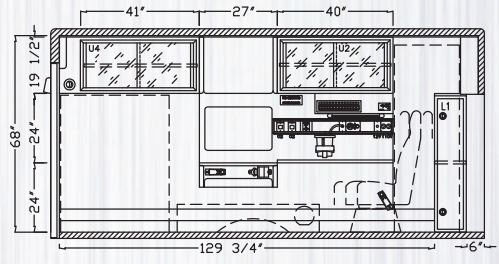
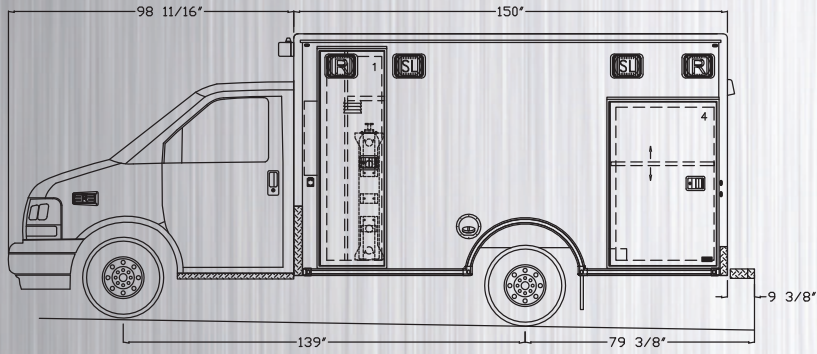

CHEVROLET G3500 DURAMEDIC



Standard Features

CHASSIS

Chevrolet G3500, 80" CA, 12,300 GVWR
NFPA Aluminum Running Boards with Splash Guard
Stainless Steel Wheel Inserts

MODULE REQUIREMENTS

Module 150" long x 92" wide
Interior headroom 68"
KKK- F, QVM and FMVSS Certified

WARRANTIES

Lifetime Modular Structural Warranty
7 Year/70,000 mile Electrical Warranty
7 Year/70,000 mile Paint Warranty
3 Year/30,000 mile Conversion Warranty

MODULE EXTERIOR

Box Pan Formed construction
Seamless CNC cut and formed .125 aluminum, side and front walls
2" x 2" Structural wall tubes, 12" on center
Module insulated with 2" polystyrene, expanding foam and 3M Thinsulate
Single piece roof sheet, continuous perimeter weld
Crowned roof
Ladder Frame floor substructure
Rigid, soundproof foam injected floor for enhanced thermal acoustic insulation
(10) module-to-chassis mount points
Double Box Pan Formed doors with Hidden Hinge
Foam injected doors with weather seal on door
Extruded door frames
Heavy duty chrome door handles with floating cam
Extruded rubber Rub Rail and fender ring with replaceable Scotchlite insert
Aluminum wheel well liners for full ounce
Drip rail over all doors with no fasteners
Exterior components installed with isolation material

MODULE COMPARTMENTS

Box Pan Formed Compartments
Sweep out compartment bottoms
Heavy duty polyurethane spray coating
Stainless steel door sills
Gas shock door hold opens
Diamond plate aluminum shelves
Maintenance free magnetic door switches
#1 Compartment oxygen storage
#2 Compartment misc. storage (optional)
#4 Compartment equipment storage
#6 Compartment spare tire storage
#8 Compartment outside access (optional)

PAINT

PPG Delfleet brand paint
Doors painted separately (paint under hinges)
Entire module base coat, clear coat with complete sand and buff

MODULE INTERIOR

All cabinets aluminum Box Pan Formed construction
Upper cabinets, hinged sliding Acrylic doors with gas shocks for restocking and cleaning
Infinitely adjustable aluminum shelves
Upper area vinyl covered, including cabinets
Vacuum formed vinyl attendant seat and cushions
Lower area plastic laminate covered, including cabinets
Stainless steel kick panels entrance doors
Gas shocks on squad bench lids
Stainless steel pull ring slam latches
Medical device rail action wall, ceiling and squad bench
Cushioned ceiling with seamless vinyl
Rubber crash protection on cabinet corners
Solid surface countertop
Overhead Grab rail and entrance door handles made from anti-microbial stainless steel
Two flip down recessed dual plasma hangers
Removable combination arm rest/waste and sharps holder at head of squad bench
Extruded 4" high, aluminum floor radius
Industrial grade linoleum, 4" up side walls
Cab to module Fluid Dam

ELECTRICAL GENERAL

All wiring color-coded for function every 3 in.
All components have separate ground wire terminated at ground buss
All devices, switches and outlets rated to 125% of maximum load
Two complete sets of as-built detailed wiring diagrams
Laminated master diagram, power distribution

VEHICLE SYSTEMS

Easy access power distribution, front bulkhead
Individual Printed Circuit Boards w/diagnostic indicators, removable automotive components
Curved rocker switches with LED indicators
Electro luminescent backlighting for switch panels and indicators
Dead front indicators as required by KKK-F
Adhesive-backed press fit removable legends
Spare switch and printed circuit board
Removable console that holds switch panel, siren, and space for two radio heads
Two RG8X antenna cable prewire

ELECTRICAL 12 VOLT DC

(2) OEM battery system wired to chassis ignition
Digital volt and amp meter with Hall Effect sensor
Battery charger prewire
12 Volt power outlets, action wall and ALS

EMERGENCY SYSTEMS

Front wall mounted 4500 halogen flasher/rotator light bar
(6) Whelen 900 Red flashing lights, sides and rear
(2) Whelen 700 Red flashing Grill lights
(2) Whelen 700 Red Cab Intersection lights
(1) Whelen 700 Amber light, center over rear doors
Chrome Trim Rings all exterior lights
Load manager/sequencer
Whelen WS-295-HFS-A1 siren with diagnostics and hands-free switching
Cast Products dual 100-watt siren speakers
Back-up alarm with cut-off switch

EXTERIOR LIGHTING

Whelen LED Marker, Clearance and License lights with Chrome trim
(6) Model 600 halogen backup/brake/turn signals
(4) Model 900 floods on sides, (2) Model 700 rear

INTERIOR LIGHTING

Whelen 86 halogen lights recessed in ceiling
60 Min. solid state restocking timer with momentary switch
200,000 candle-power handheld spotlight
Action wall counter light

ELECTRICAL 110 VOLT AC

15-amp straight blade shore power w/toggle GFI
(2) Hospital grade illuminated outlets, action wall and ALS cabinet
Prewire for Vanner inverter

ENVIRONMENTAL SYSTEMS

Combination 23,000 heat, 32,000 cool, 650 CFM system
Conditioned air distribution face of cabinet and hidden return air at ALS
Single, speed 100 CFM exhaust fan

MEDICAL SYSTEMS

Single center position, Ferno or Stryker cot fastener
Medical oxygen outlets, (2) action wall and (1) head of squad bench
Electric oxygen low pressure control with manual bypass
SSCOR onboard suction system with regulator and canister
Zico universal 7"-9" diameter cylinder holder